



Avocent®

# Emerge® EMS

Installer/User Guide





## **INSTRUCTIONS**

This symbol is intended to alert the user to the presence of important operating and maintenance (servicing) instructions in the literature accompanying the appliance.



# **Emerge<sup>®</sup> EMS**

## **Installer/User Guide**

Avocent, the Avocent logo, The Power of Being There and Emerge are registered trademarks of Avocent Corporation. All other marks are the property of their respective owners.

© 2005 Avocent Corporation. All rights reserved.

## European approvals

### European EMC directive 89/336/EEC



This equipment has been tested and found to comply with the limits for a class A computing device in accordance with the specifications in the European standard EN55022. These limits are designed to provide reasonable protection against harmful interference. This equipment generates, uses and can radiate radio frequency energy and if not installed and used in accordance with the instructions may cause harmful interference to radio or television reception. However, there is no guarantee that harmful interference will not occur in a particular installation. If this equipment does cause interference to radio or television reception, which can be determined by turning the equipment on and off, the user is encouraged to correct the interference with one or more of the following measures: (a) Reorient or relocate the receiving antenna. (b) Increase the separation between the equipment and the receiver. (c) Connect the equipment to an outlet on a circuit different from that to which the receiver is connected. (d) Consult the supplier or an experienced radio/TV technician for help.

# TABLE OF CONTENTS

<b>List of Figures .....</b>	<b>v</b>
<b>Chapter 1: Product Overview .....</b>	<b>1</b>
<i>Features and Benefits .....</i>	<i>1</i>
<i>Configuration Possibilities .....</i>	<i>1</i>
<i>Further Expansion .....</i>	<i>3</i>
<i>Safety Precautions.....</i>	<i>4</i>
<b>Chapter 2: Installation .....</b>	<b>5</b>
<i>Locations .....</i>	<i>5</i>
<i>Mounting .....</i>	<i>6</i>
<i>Making Standard Connections .....</i>	<i>8</i>
<i>Connections at the Transmitter .....</i>	<i>8</i>
<i>Connections at the Receiver.....</i>	<i>13</i>
<i>Making Cascade Connections.....</i>	<i>16</i>
<b>Chapter 3: Operations .....</b>	<b>23</b>
<i>Indicators .....</i>	<i>23</i>
<i>Adjustments .....</i>	<i>24</i>
<i>Brightness and Sharpness Adjustments.....</i>	<i>24</i>
<i>Skew Compensation Adjustments (Emerge EMS1000MP-R Receivers Only).....</i>	<i>25</i>
<b>Appendices .....</b>	<b>29</b>
<i>Appendix A: Technical Support .....</i>	<i>29</i>
<i>Appendix B: Troubleshooting.....</i>	<i>30</i>
<b>Index.....</b>	<b>31</b>



## LIST OF FIGURES

<i>Figure 1.1: A standard Emerge EMS1000P configuration driving two display/speakers sets.....</i>	<i>1</i>
<i>Figure 1.2: A typical Emerge EMS1000MP configuration driving up to eight displays.....</i>	<i>2</i>
<i>Figure 1.3: Cascaded transmitters .....</i>	<i>3</i>
<i>Figure 1.4: Cascaded receivers .....</i>	<i>3</i>
<i>Figure 2.1: Applying the self adhesive rubber feet .....</i>	<i>6</i>
<i>Figure 2.2: The rear mounting slot .....</i>	<i>6</i>
<i>Figure 2.3: Placing an Emerge EMS unit within the optional rack mount chassis .....</i>	<i>7</i>
<i>Figure 2.4: Connecting video and audio signals from the source PC system.....</i>	<i>8</i>
<i>Figure 2.5: Connecting a monitor and speakers to the transmitter unit.....</i>	<i>9</i>
<i>Figure 2.6: Overall maximum link length (1000 feet) when one receiver is connected.....</i>	<i>10</i>
<i>Figure 2.7: Connecting the link cable to the EMS1000P transmitter unit.....</i>	<i>10</i>
<i>Figure 2.8: Connecting up to four link cables to the EMS1000MP-T transmitter unit .....</i>	<i>11</i>
<i>Figure 2.9: Connecting the power adaptor to the transmitter unit.....</i>	<i>12</i>
<i>Figure 2.10: Connecting the power adaptor to the power cord.....</i>	<i>12</i>
<i>Figure 2.11: Connecting displays and speakers to the receiver unit .....</i>	<i>13</i>
<i>Figure 2.12: Overall maximum link length (1000 feet) when one receiver is connected.....</i>	<i>14</i>
<i>Figure 2.13: Connecting the link cable to the receiver unit.....</i>	<i>14</i>
<i>Figure 2.14: Connecting the power adaptor to the receiver unit.....</i>	<i>15</i>
<i>Figure 2.15: Connecting the power adaptor to the power cord.....</i>	<i>15</i>
<i>Figure 2.16: Valid multiple cascade connections and their effects on overall link lengths .....</i>	<i>17</i>
<i>Figure 2.17: Connecting multiple transmitters in a cascade arrangement.....</i>	<i>18</i>
<i>Figure 2.18: Connecting the audio/visual outputs of one transmitter to the inputs of the next .....</i>	<i>19</i>
<i>Figure 2.19: Connecting multiple receivers in a cascade arrangement .....</i>	<i>20</i>
<i>Figure 2.20: Connecting the link output of one receiver to the link input of the next.....</i>	<i>21</i>
<i>Figure 3.1: Location of the red and green operation indicators .....</i>	<i>23</i>
<i>Figure 3.2: Location of the brightness and sharpness adjustment dials.....</i>	<i>24</i>
<i>Figure 3.3: Using a high contrast image to assist with sharpness adjustments .....</i>	<i>24</i>
<i>Figure 3.4: Location of the skew compensation adjustment dials .....</i>	<i>25</i>
<i>Figure 3.5: Creating a suitable skew test pattern within a paint package.....</i>	<i>25</i>
<i>Figure 3.6: The supplied skew test pattern showing green slightly retarded relative to the red and blue.....</i>	<i>26</i>
<i>Figure 3.7: A skew compensation dial showing its middle neutral position and its two maximum positions .....</i>	<i>26</i>
<i>Figure 3.8: The two skew compensation dials showing how they affect each of the colors.....</i>	<i>27</i>



# Product Overview

## Features and Benefits

The Avocent Emerge® EMS series of media streaming products empower you to distribute your analog video and stereo sound to many remote destinations. Using standard UTP structured cabling, you can deliver very high video resolutions to multiple display screens located up to 1000 feet (600 feet for EMS1000P models) away from the source PC system. The high quality circuitry housed within every Emerge EMS product ensures that both image and sound are true to their source.

The standard configuration of an Emerge EMS transmitter and receiver pair is only the beginning. Thanks to sensible design and no-nonsense build quality you can expand your installation at any time using additional Emerge EMS units to keep pace with your project.

## Configuration Possibilities

There are two different Emerge EMS transmitter/receiver types available, the choice of which unit you use depends upon how many display/speaker locations need to be driven:

**Emerge EMS1000P** provides a single transmitter and single receiver capable of directly supporting two remote screen and speaker sets. The transmitter can additionally support a local screen and speaker set located adjacent to the source system. Expansion is made possible by connecting further EMS1000P transmitters to the original unit, each supporting their own EMS1000P receiver units.

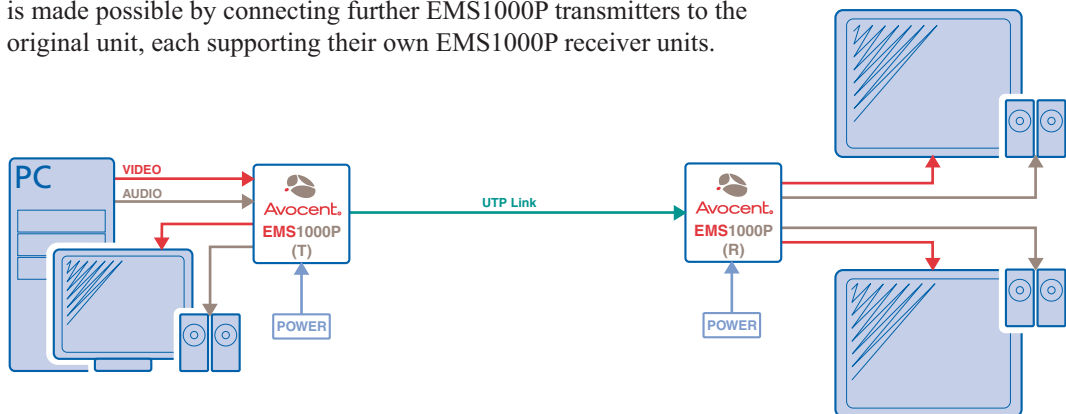

Figure 1.1: A standard Emerge EMS1000P configuration driving two display/speakers

**Emerge EMS1000MP** units are designed to provide potentially enormous expansion possibilities from the outset. Each EMS1000MP-T transmitter is capable of directly feeding up to four EMS1000MP-R receivers. Each receiver supports two remote screen and speakers sets, but additionally can also drive a further three receivers and their respective screens/speakers. Additional expansion is also possible by connecting further EMS1000MP-T transmitters to the original unit, each supporting their own multiple EMS1000MP-R receiver units.

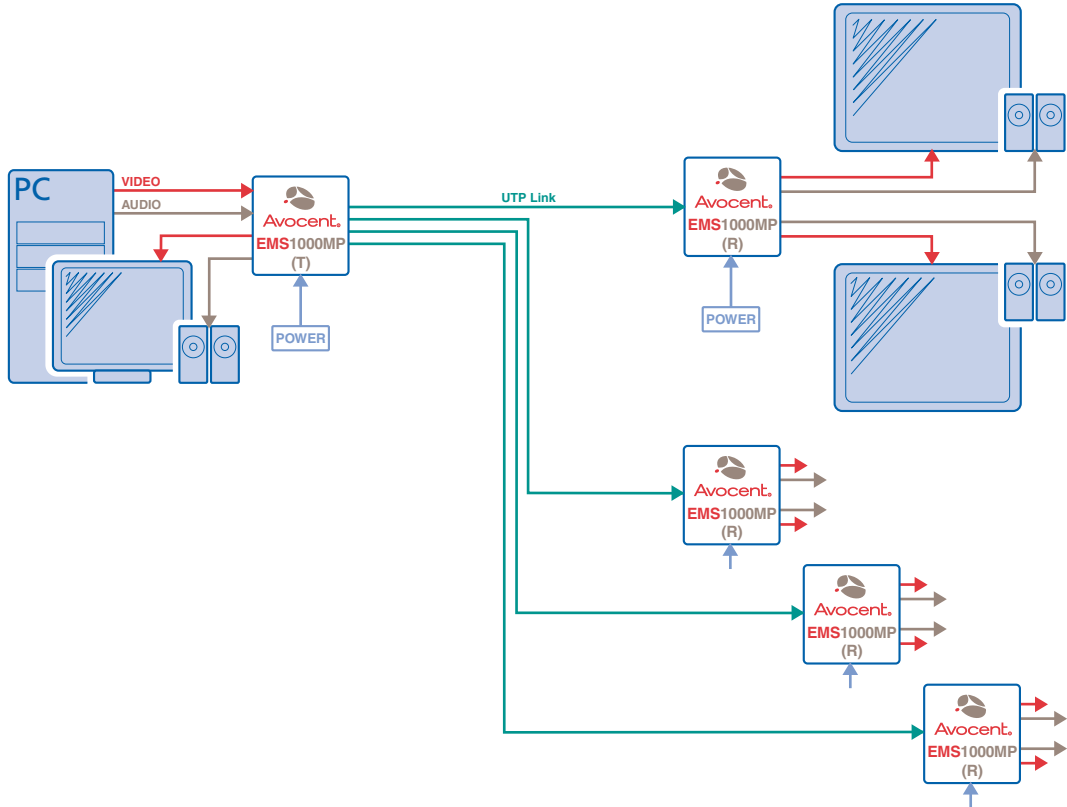

Figure 1.2: A typical Emerge EMS1000MP configuration driving up to eight displays

## Further Expansion

### Transmitter Cascading

As mentioned earlier, the EMS1000P and EMS1000MP-T transmitters are both capable of supporting additional transmitter (and their subsequent receiver) units. This is achieved using the video and audio out ports to provide the inputs into the next transmitter unit, and so on. A limit of three cascade connections (comprising both transmitter and/or receiver cascades) is possible within any branch of the system.

Figure 1.3: Cascaded transmitters

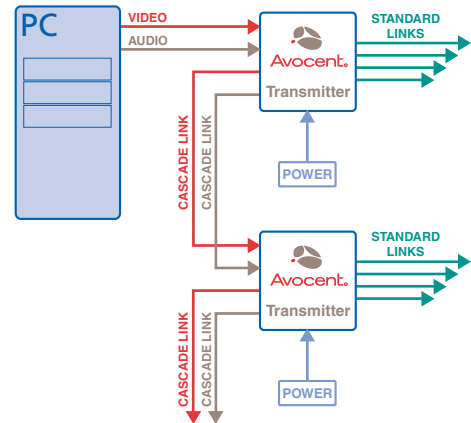

### Receiver Cascading

This method of expansion is limited to the EMS1000MP-R receivers as only they are equipped with the necessary **LINK OUT** cascade port. Using the **LINK OUT** port, the video and audio signals are transferred via UTP cabling to the next receiver. This receiver can then drive its own dual screen/speaker sets as well as provide a further **LINK OUT** to a third and final EMS1000MP-R receiver. A limit of three cascade connections (comprising both transmitter and/or receiver cascades) is possible within any branch of the system.

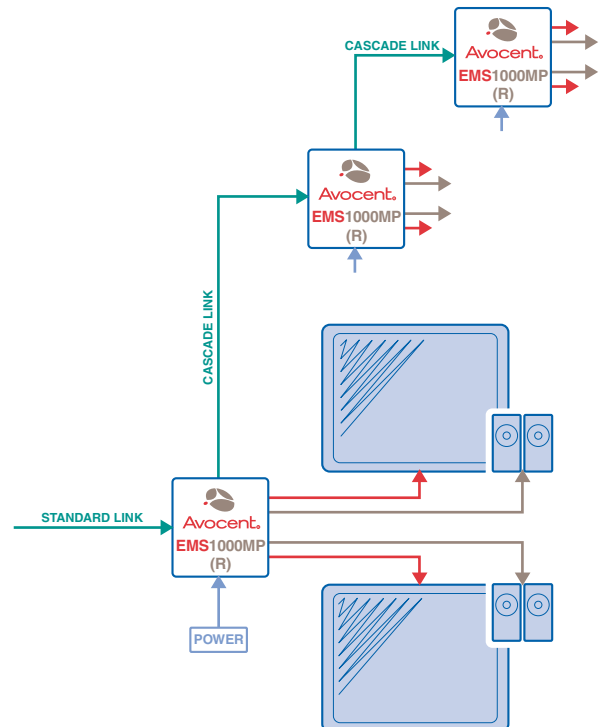

Figure 1.4: Cascaded receivers

## Safety Precautions

- For use in dry, oil-free indoor environments only.
- Do not use to link between buildings.
- Not suitable for use in hazardous or explosive environments or next to highly flammable materials.
- Ensure that all twisted pair interconnect cables are installed in compliance with all applicable wiring regulations.
- Do not connect UTP link interfaces (RJ45 style connectors) to any other equipment, particularly network or telecommunications equipment.
- Warning – the power adaptor contains live parts. No user serviceable parts are contained within the power adaptor - do not dismantle.
- Do not use the power adaptor if the power adaptor case becomes damaged, cracked or broken or if you suspect that it is not operating properly. Replace the power adaptor with a manufacturer approved type only.
- The Emerge units do not provide ground isolation and should not be used for any applications that require ground isolation or galvanic isolation.
- Use only with grounded outlets at both the computer and monitor. When using a backup power supply (UPS), power the computer, the monitor and the Emerge unit off the supply.
- If the building has 3-phase AC power, ensure that the computer and monitor are on the same phase. For best results, they should be on the same circuit.
- The primary means to cease operation of the units is to remove the power adaptor lead. Ensure that the power adaptor is positioned near to the equipment and is easily accessible.
- Test AC outlets at the computer and monitor for proper polarity and grounding.
- Do not use a 2-wire extension cord in any Avocent product configuration.
- If you use a power extension cord with the Emerge units, make sure the total ampere rating of the devices plugged into the extension cord do not exceed the cord's ampere rating. Also, make sure that the total ampere rating of all the devices plugged into the wall outlet does not exceed the wall outlet's ampere rating.
- Do not attempt to service the Emerge units yourself.
- The Emerge units and power adaptors can get warm in operation – do not situate them in an enclosed space without any ventilation.
- For correct operation, the local and remote units must have ground connections. At the computer end, this is achieved by ensuring that the computer that the Emerge unit is connected to has a ground connection. At the audio/visual device end, this can be achieved by ensuring that the power supply is connected to a grounded power outlet. Alternatively, a ground connection will be made via the monitor, if the monitor is itself grounded.
- Where possible, try to avoid laying the interconnect cable(s) alongside power cables.

## *Installation*

### Locations

Please consider the following important points when planning the positions of your Emerge EMS units:

- Take care not to exceed the maximum link cable lengths (please refer to the section [Making Cascade Connections](#)).
- Ensure that the transmitters are as close as possible to the source PC system and the receivers are similarly close to the display units. Use video connection cables that are correctly shielded and are no longer than 6 feet in length.
- Choose routes for the twisted pair link cables that avoid mains power cables as much as possible.
- Remember a mains power socket is required for each transmitter and receiver.

## Mounting

Before you begin connecting to the source PC system and display units, it is advisable to mount the Emerge EMS units in place. There are a number of mounting possibilities for the transmitter and receiver units:

- On a horizontal surface using the supplied self adhesive feet,
- Mounted on a screw using the rear slot,
- Within the optional rack mount chassis,
- On inclined surfaces using self adhesive Velcro® strips (not supplied).

### Using the supplied self adhesive feet

Apply the supplied self-adhesive rubber feet to the underside corners of the Emerge EMS units.

Figure 2.1: Applying the self adhesive rubber feet

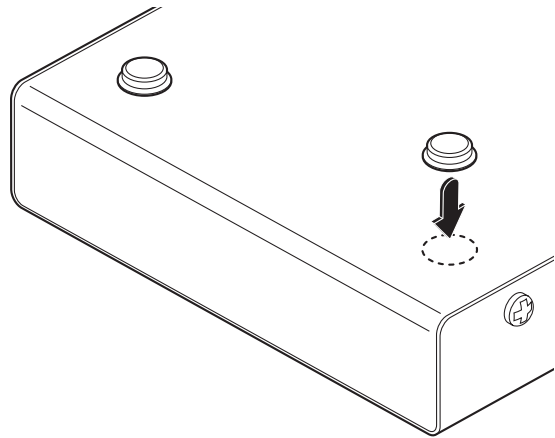

### Using the rear mounting slot

The slot at the rear of each unit allows it to be hung upon a fixed screw that protrudes from the mounting surface.



**IMPORTANT:** The internal circuit board is accessible through the mounting slot. Ensure that the mounting screw protrudes no further than  $\frac{1}{2}$ " (12.5mm) into the unit casing - serious electrical damage will be caused if the screw makes contact with the internal circuitry.

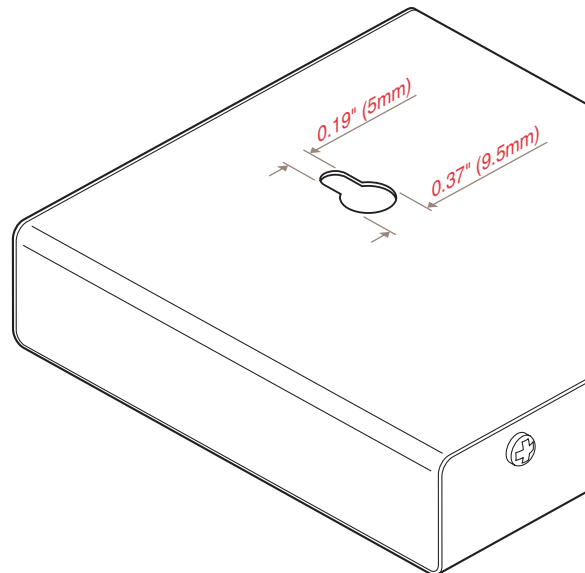

Figure 2.2: The rear mounting slot

### Using the optional rack mount chassis

1. Place the optional rack plate onto the front of the transmitter or receiver unit and secure it with countersunk screws.
2. Orient the unit on its side so that its labeled face is the correct way up and the securing plate is facing away from the rack.
3. Slide the unit into the required rack position.
4. The rack mount chassis has a series of holes in its floor that are spaced to accommodate the screws on the unit's lower edge. Ensure that the screws correctly locate into the holes of the chosen slot. The rack securing plate on the unit should now be flush with the front of the rack mount chassis.
5. Use a (pan-head) screw in the top hole of the rack securing plate to fasten the unit to the rack.

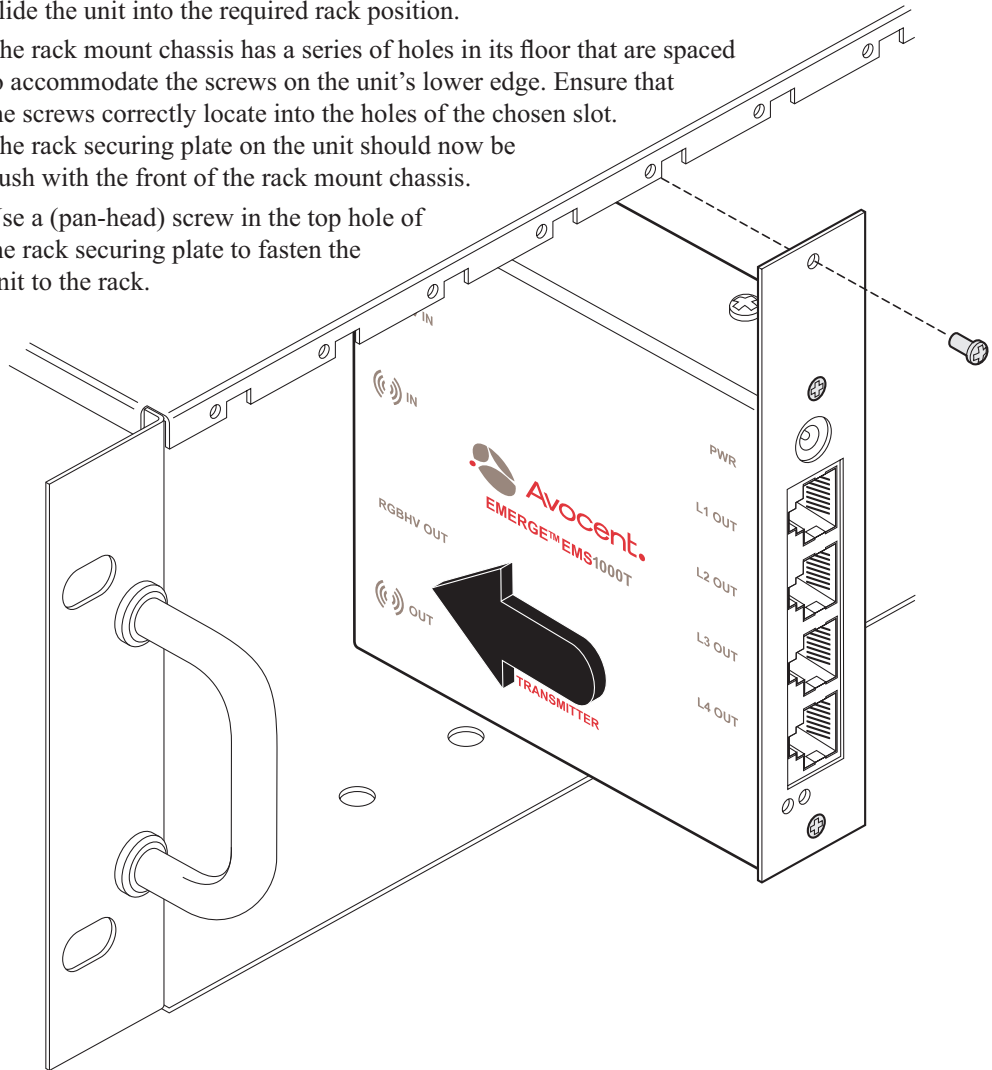

Figure 2.3: Placing an Emerge EMS unit within the optional rack mount chassis

## Making Standard Connections

Connections to the Emerge units do not need to follow the precise order given in this user guide although it is recommended that you do not apply power to the units until all other connections have been made.

**Note:** Unless stated otherwise, all connection information given here applies to both the Emerge EMS1000P and EMS1000MP series products.

### Connections at the Transmitter

#### To Connect Video and Audio from the Source PC System

1. Attach a video cable of suitable type and length (fully shielded with 15 way male D-type connectors at both ends – 6 feet or less) to the socket labeled **RGBHV IN** on the Emerge EMS transmitter.
2. Attach the other end of the video cable to the appropriate VGA video output socket on the source PC system.
3. Attach a stereo audio cable (shielded with three way 3.5mm jack plugs at both ends) to the socket labeled **IN** on the Emerge EMS transmitter.
4. Attach the other end of the stereo audio cable to the appropriate audio output socket on the source PC system.

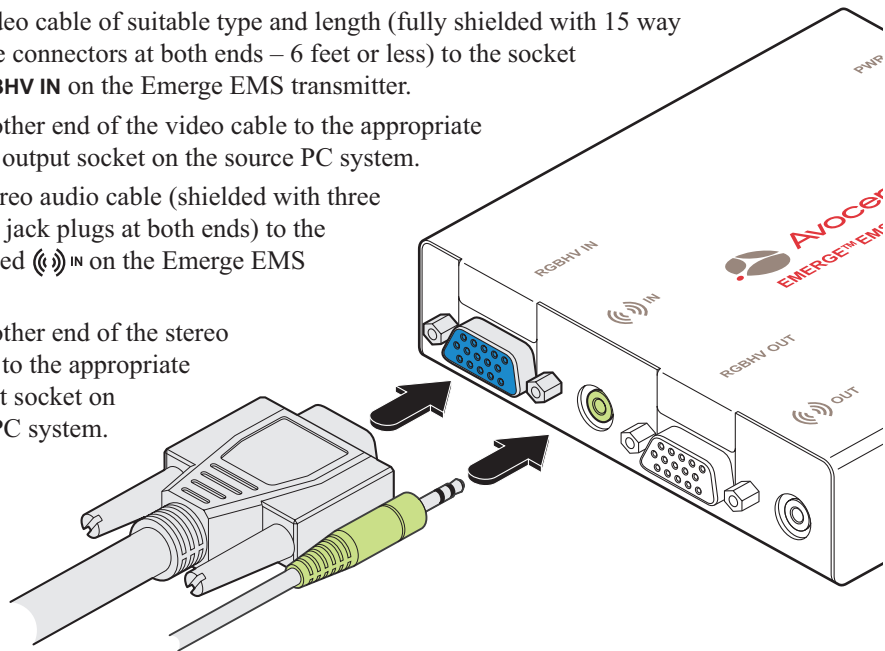

Figure 2.4: Connecting video and audio signals from the source PC system

## To Connect a Monitor and Speakers

The video and audio out ports of the Emerge EMS transmitter can optionally be used either to:

- Attach a monitor and/or speakers in the vicinity of the source PC system – See below,
- or**
- Make a cascade link to another transmitter unit – Please refer to the section [Making Cascade Connections – To Connect Cascaded Transmitters](#).

1. Attach the video cable from the monitor to the socket labeled **RGBHV OUT** on the Emerge EMS transmitter.
2. Attach the stereo audio cable from the speakers to the socket labeled **(Ⓜ) OUT** on the Emerge EMS transmitter.

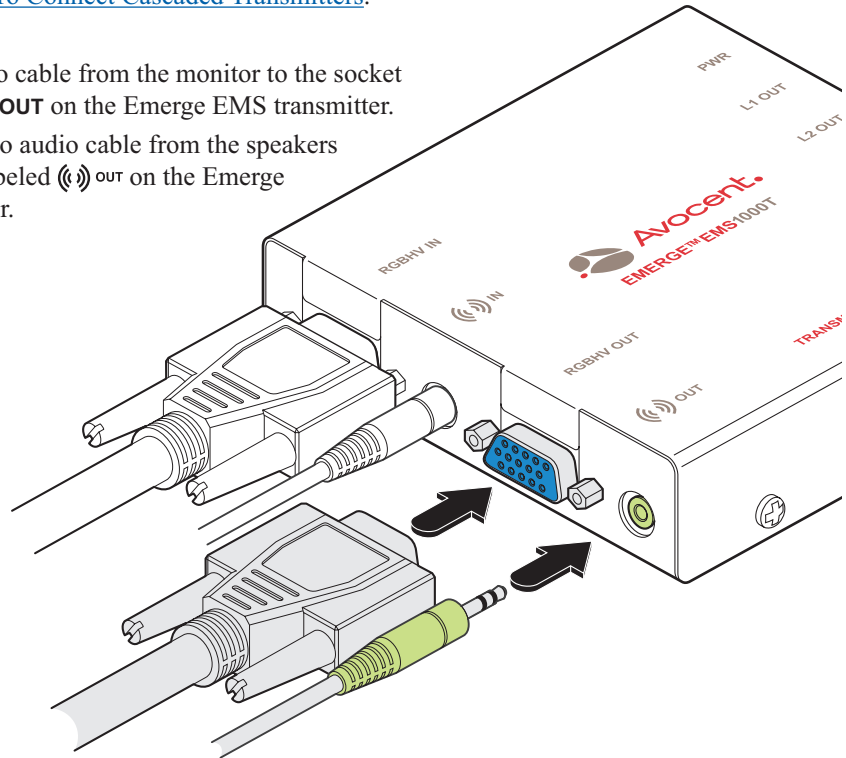

Figure 2.5: Connecting a monitor and speakers to the transmitter unit

## To Connect the Link Cable(s)

The links between the transmitter and receiver units are made using between one and four twisted pair cables, specified to Category 5 or higher. Each cable carries video and audio signals to each receiver unit.

When a single receiver is attached to a link cable, the maximum length of that link cable is 1000 feet (600 feet for EMS1000P models).

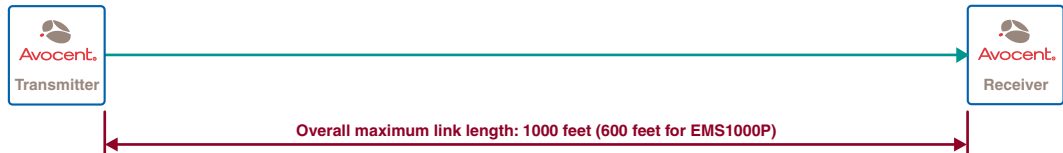

Figure 2.6: Overall maximum link length (1000 feet) when one receiver is connected

However, if further receivers are connected in cascade to the initial receiver using its **LINK OUT** port (Emerge EMS1000MP-R models only), then the overall length of the link cables used must be reduced. For further information, please refer to the section [Making Cascade Connections](#).

---

**NOTE:** Where possible, avoid laying the twisted pair link cable(s) alongside power cables.

---

### Emerge EMS1000P models

1. Attach the connector of the link cable to the socket labeled **LINK** on the Emerge EMS1000P transmitter. There should be a click when the cable is fully inserted and locked in place.

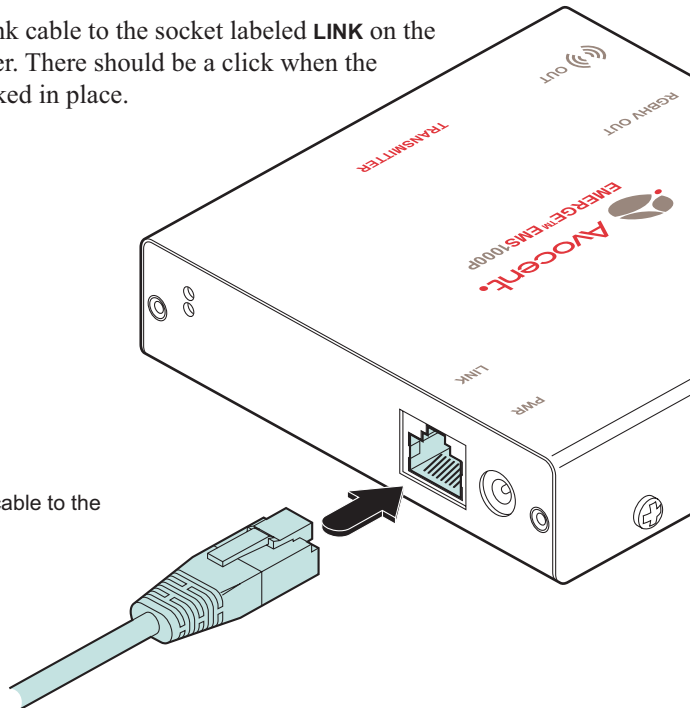

Figure 2.7: Connecting the link cable to the EMS1000P transmitter unit

### Emerge EMS1000MP-T models

1. Attach the connector of the first link cable to the socket labeled **L1 OUT** on the Emmerge EMS1000MP-T transmitter. There should be a click when the cable is fully inserted and locked in place.
2. Attach the connectors of the remaining link cables to the sockets labeled **L2 OUT** to **L4 OUT**, as required.

In all cases, there should be a click when the cable is fully inserted and locked in place.

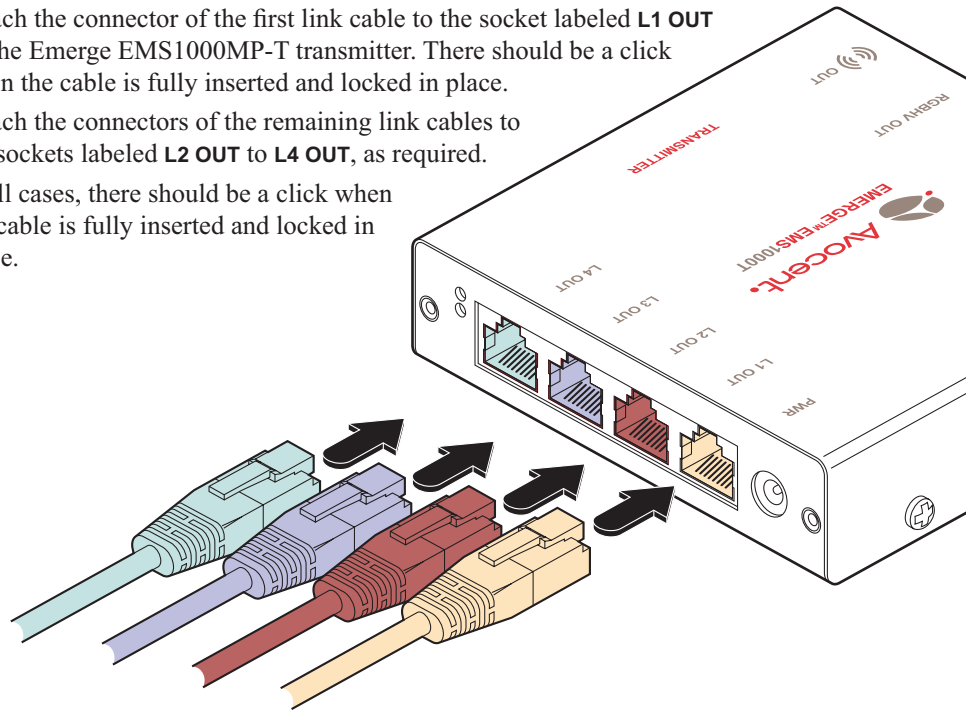

Figure 2.8: Connecting up to four link cables to the EMS1000MP-T transmitter unit

## To Connect the Power Adaptor



**NOTE:** Please read and adhere to the electrical safety information given within the [Safety Precautions](#) section of this guide. In particular, do not use a 2-wire (unearthed) extension cord.

1. Locate the supplied power adaptor and attach its output connector to the socket labeled **PWR** on the Emerge EMS transmitter.

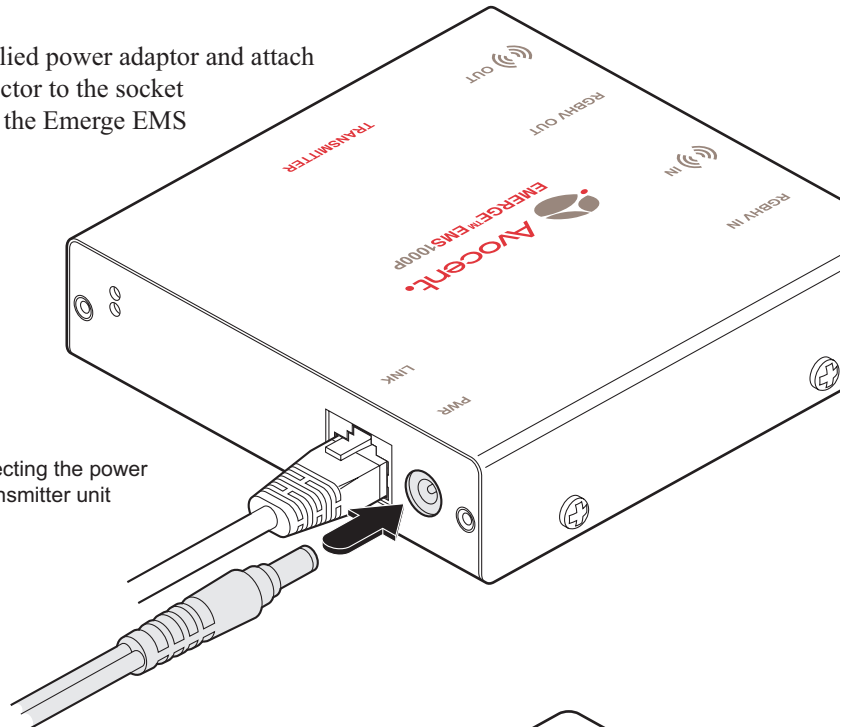

Figure 2.9: Connecting the power adaptor to the transmitter unit

2. Insert the IEC connector of the supplied power cord into the corresponding socket of the power supply.
3. When all other connections have been made at the transmitter and receiver units, connect the other end of the power cord to a nearby earthed mains socket.

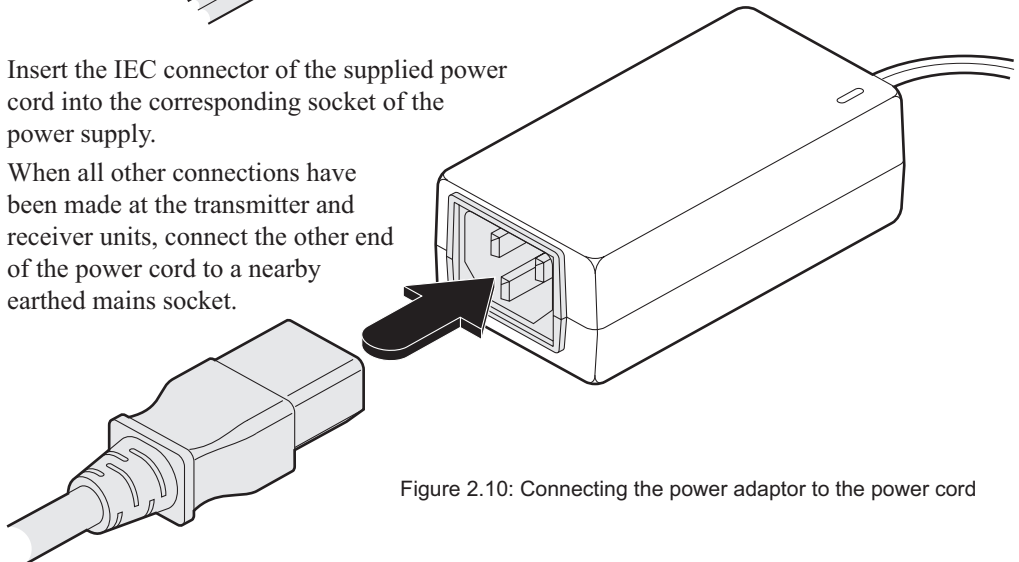

Figure 2.10: Connecting the power adaptor to the power cord

## Connections at the Receiver

### To Connect Displays and Speakers

Dual video and audio outputs are provided on the Emerge EMS receiver. Both sets of ports provide identical signals and their connection procedures are the same:

1. Attach the video cable from the display unit to the socket labeled **RGBHV OUT** on the Emerge EMS receiver.
2. Attach the stereo audio cable from the speakers (or amplifier) to the socket labeled **(( )) OUT** on the Emerge EMS receiver.

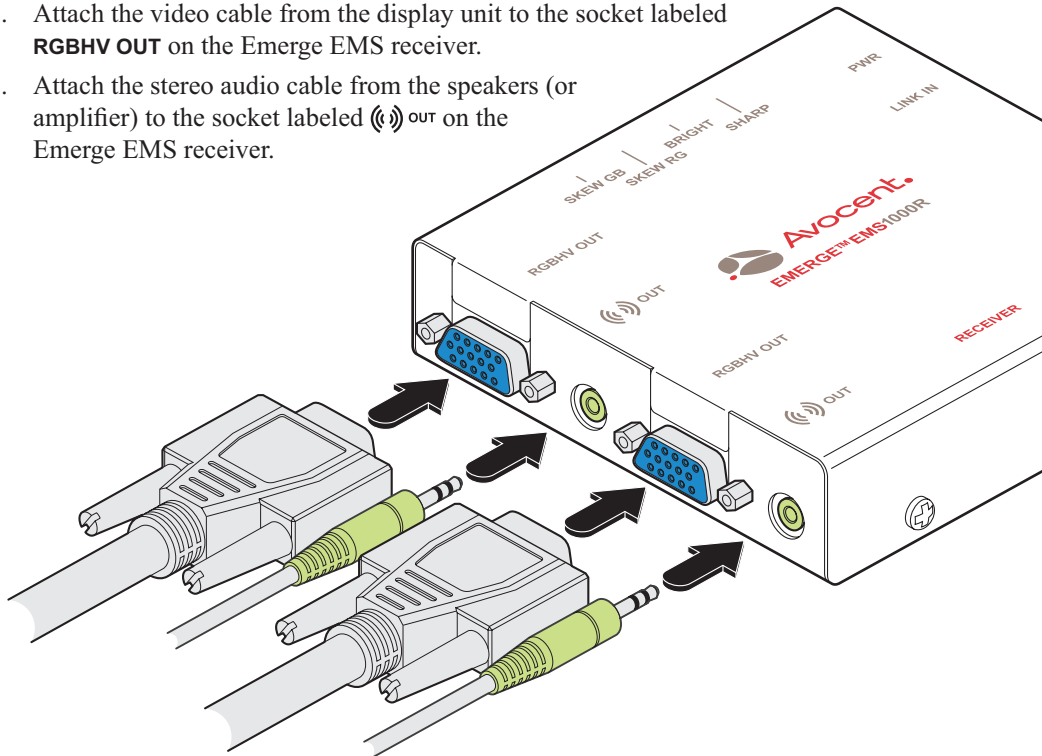

Figure 2.11: Connecting displays and speakers to the receiver unit

## Link In

The link from the transmitter to each receiver unit is made using a twisted pair cable, specified to Category 5 or higher.

When a single receiver is attached to a link cable, the maximum length of that link cable is 1000 feet (600 feet for EMS1000P models).

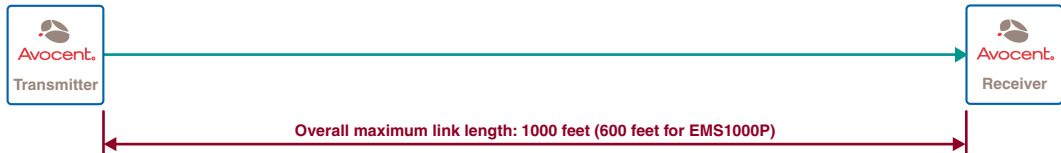

Figure 2.12: Overall maximum link length (1000 feet) when one receiver is connected

However, if further receivers are connected in cascade to the initial receiver (using the **LINK OUT** port – Emerge EMS1000MP-R models only), then the overall length of the link cables used must be reduced. For further information, please refer to the section [Making Cascade Connections](#).

---

**NOTE:** Where possible, avoid laying the twisted pair link cable(s) alongside power cables.

---

1. Attach the connector of the link cable to the socket labeled **LINK IN** on the Emerge EMS receiver. There should be a click when the cable is fully inserted and locked in place.

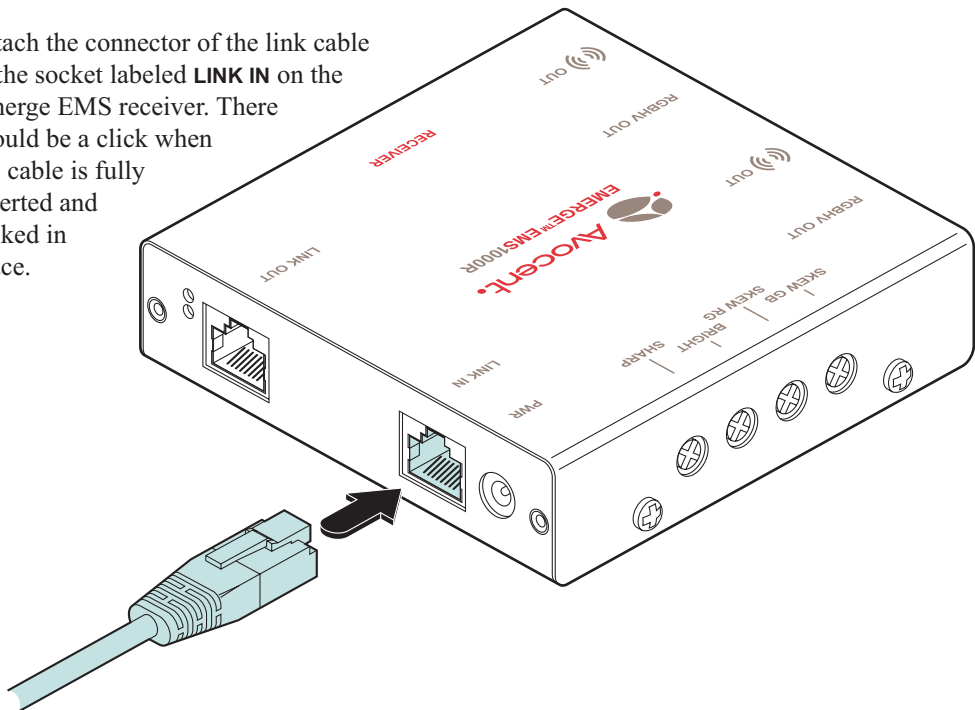

Figure 2.13: Connecting the link cable to the receiver unit

## To Connect the Power Adaptor



**NOTE:** Please read and adhere to the electrical safety information given within the [Safety Precautions](#) section of this guide. In particular, do not use a 2-wire (unearthed) extension cord.

1. Locate the supplied power adaptor and attach its output connector to the socket labeled **PWR** on the Emerge EMS receiver.

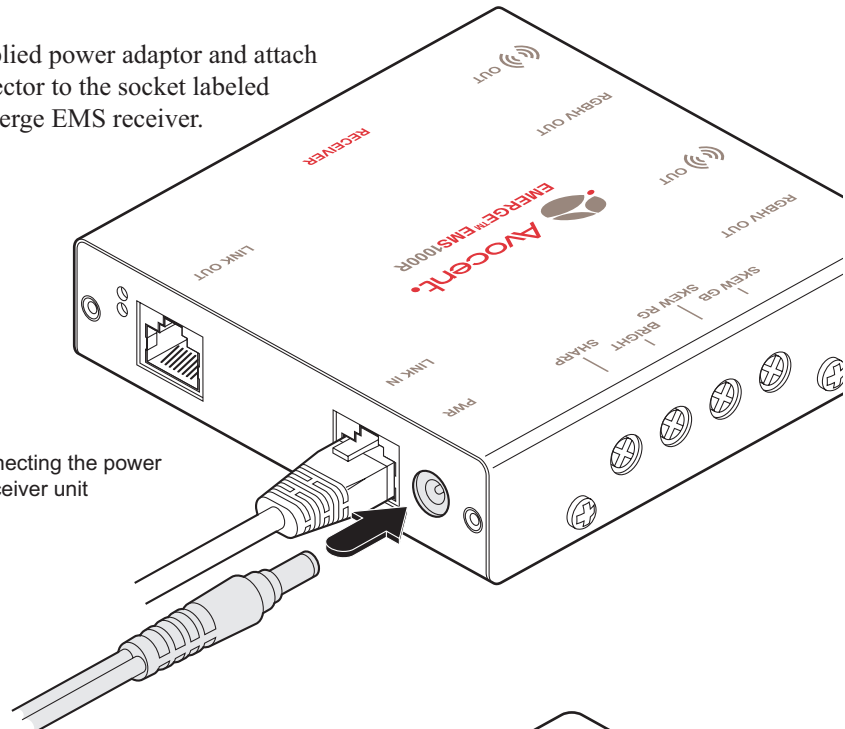

Figure 2.14: Connecting the power adaptor to the receiver unit

2. Insert the IEC connector of the supplied power cord into the corresponding socket of the power supply.
3. When all other connections have been made at the transmitter and receiver units, connect the other end of the power cord to a nearby earthed mains socket.

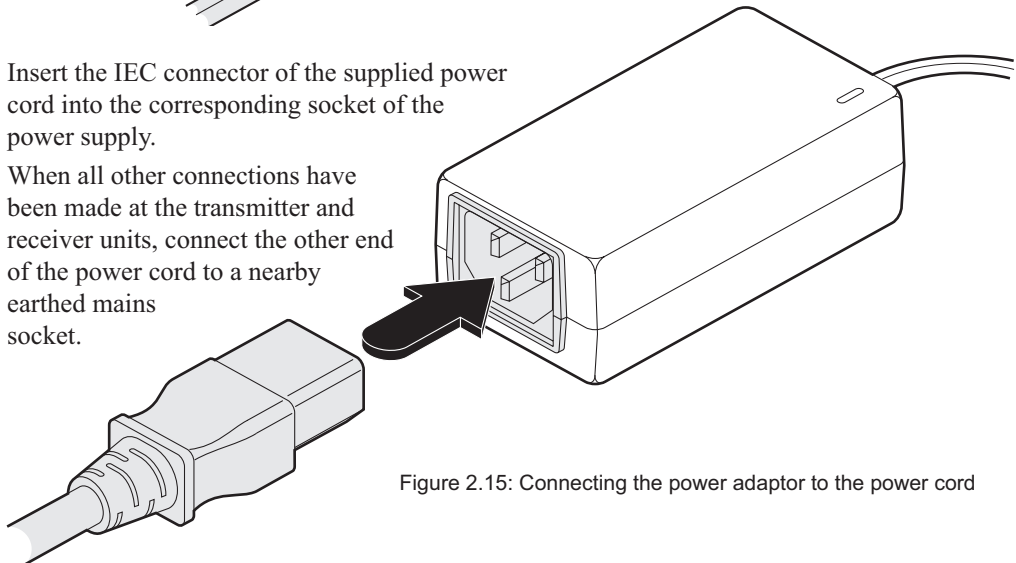

Figure 2.15: Connecting the power adaptor to the power cord

## Making Cascade Connections

The Emerge EMS series of products have been specifically designed to be flexible in order to support both your immediate and future needs for media streaming. In addition to the standard connections made from transmitters to receivers, you can also link extra transmitters to transmitters and/or receivers in order to provide more display/speaker outputs. These non-standard links are called *cascade connections*.

### Important Limitations When Cascading Emerge EMS units

- There should never be more than **three** cascade connections between the *Primary Transmitter* (the one connected to the source PC) and any receiver. The cascade connections can all occur at the transmitter end or all at the receiver end (EMS1000MP-R only) or at a mixture of both.
- Each cascade connection reduces the overall link length permissible from a transmitter to the final receiver in a branch. To calculate the recommended overall maximum link length for a branch, count the number of cascade connections between the *Primary Transmitter* and the final receiver in that branch. The effects of cascade connections on overall branch link lengths are as follows:

Table 2.1: How cascade connections affect overall maximum link cable lengths (EMS1000MP)

Number of cascade connections (in a branch)	Overall length of links for the branch (from transmitter to furthest receiver)
0	1000 feet (300m)
1	800 feet (250m)
2	650 feet (200m)
3	600 feet (175m)

### Notes

EMS1000P models should always be limited to link lengths of 600 feet or less, regardless of cascade connections, due to a lack of skew compensation adjustments.

The lengths of transmitter cascade connections should never be longer than 6 feet (2m) and can be considered to have a negligible effect upon overall link lengths.

The maximum resolutions achievable are: 1600 x 1200 x 60 Hz at 200m and 1280 x 1024 x 60Hz at 300m. If you are using lower resolutions then it may be possible to achieve longer transmission distances than shown in the above table although we do not recommend runs longer than 1000ft in any installation. If you are running shorter cables then it may be possible to use more cascades than shown in the above table.

### Cascade connection examples

These examples demonstrate valid configurations and the effect of cascade connections upon overall link lengths:

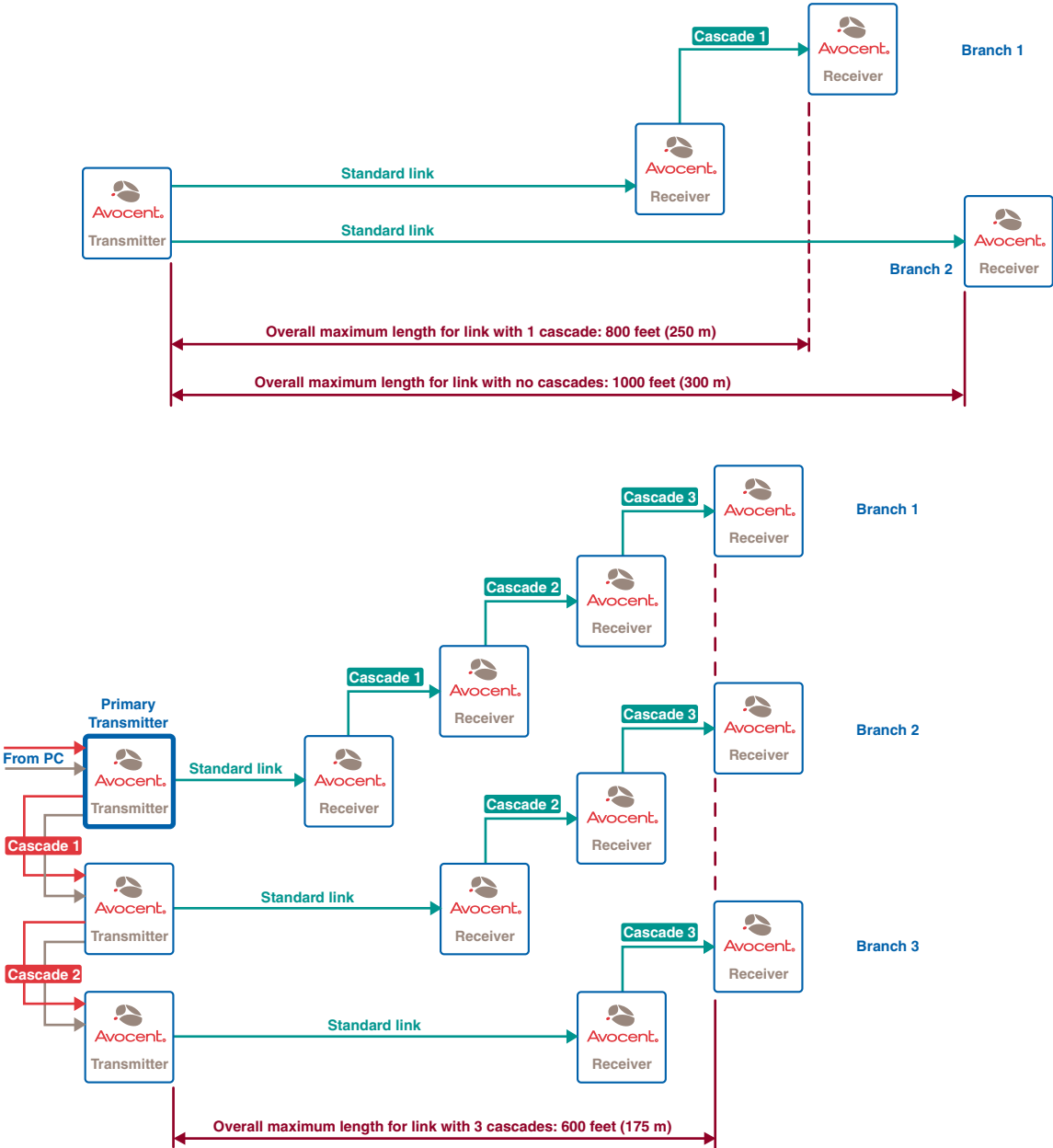

Figure 2.16: Valid multiple cascade connections and their effects on overall link lengths

## Cascading Transmitters

Expansion at the transmitter end is achieved using the video and audio output ports. The signals from these ports are connected to the video and audio inputs of the next transmitter and so on. Emerge EMS1000P and EMS1000MP-T transmitters can be mixed in a cascade in any order using the method discussed here.

---

**NOTE:** Ensure that there are no more than three cascades (transmitter or receiver cascades) between the primary transmitter and the furthest receiver in any branch.

---

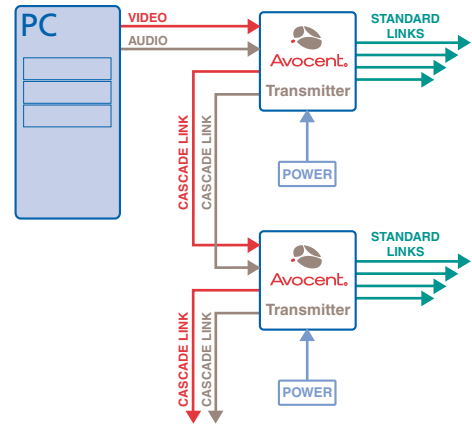

Figure 2.17: Connecting multiple transmitters in a cascade arrangement

## To Connect Cascaded Transmitters

1. Attach a video cable of suitable type and length (fully shielded with 15 way male D-type connectors at both ends – 6 feet or less) to the socket labeled **RGBHV OUT** on the primary Emerge EMS transmitter.
2. Attach the other end of the video cable to the socket labeled **RGBHV IN** on the secondary Emerge EMS transmitter.
3. Attach a stereo audio cable (shielded with three way 3.5mm jack plugs at both ends) to the socket labeled **(Ⓜ) OUT** on the primary Emerge EMS transmitter.
4. Attach the other end of the stereo audio cable to the socket labeled **(Ⓜ) IN** on the secondary Emerge EMS transmitter.
5. Repeat such cascade links until the required number of transmitters (up to a maximum of four) are present. Connect the remaining signal and power cables to the added transmitters (and their respective receivers) as discussed earlier within this chapter.

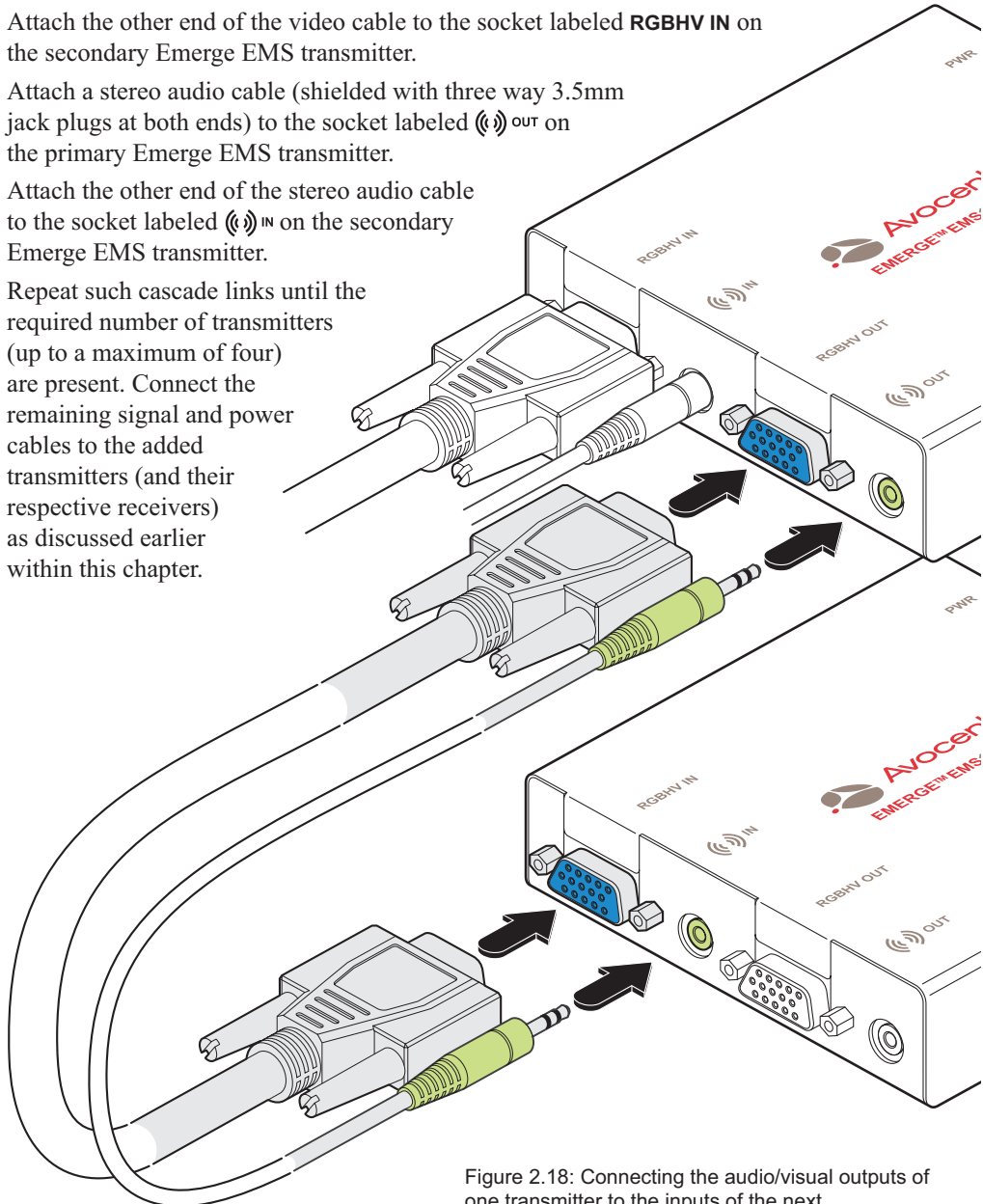

Figure 2.18: Connecting the audio/visual outputs of one transmitter to the inputs of the next

### Cascading Receivers (Emerge EMS1000MP-R Receivers Only)

Expansion at the receiver end is made possible using the **LINK OUT** ports present on Emerge EMS1000MP-R receivers. Receiver cascade links are made using twisted pair cables, specified to Category 5 or higher.

**NOTE:** Ensure that there are no more than three cascades (transmitter or receiver cascades) between the primary transmitter and the furthest receiver in any branch.

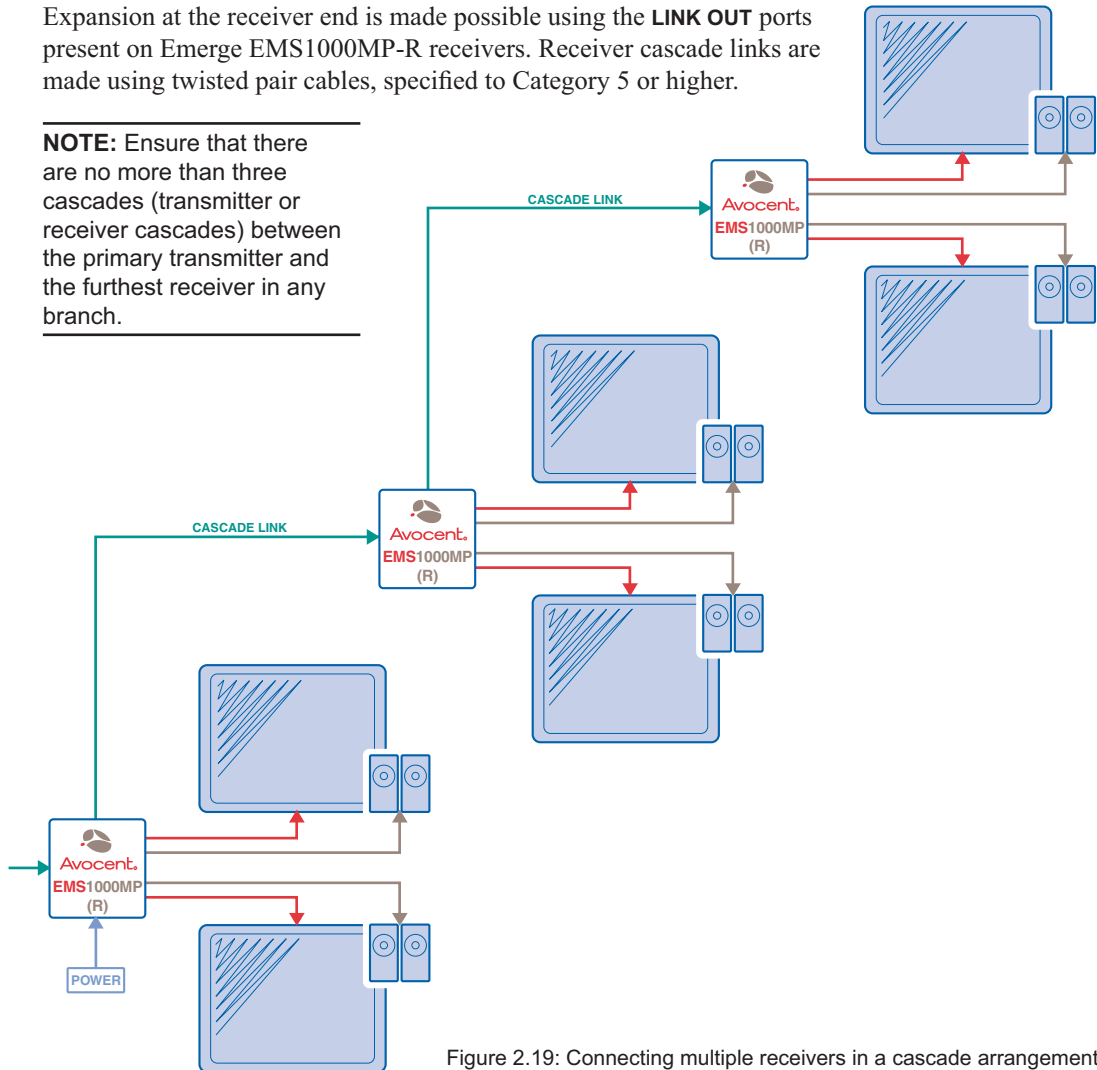

Figure 2.19: Connecting multiple receivers in a cascade arrangement

### Video Image Adjustments

As link cable lengths increase and more receivers are cascaded, color separation effects may become noticeable within displayed video images, particularly at higher resolutions. These effects are called 'skew' and result from differing delays on the red, green and blue color signals as they travel to the receivers. Each Emerge EMS1000MP-R receiver provides two extra adjustment dials to counter skew effects. For further information, please refer to the section [Skew Compensation Adjustments](#) within Chapter 3.

## To Connect Cascaded Receivers

**NOTE:** Please observe the recommended overall link cable lengths (including receiver cascade connections) in order to avoid signal degradation.

1. Attach the connector of the cascade link cable to the socket labeled **LINK OUT** on the primary Emerge EMS1000MP-R receiver.
2. At the other end of the cascade link cable, attach the connector to the socket labeled **LINK IN** on the secondary Emerge EMS1000MP-R receiver.  
In all cases, there should be a click when the cable is fully inserted and locked in place.
3. If necessary, repeat the above procedure for a tertiary Emerge EMS1000MP-R receiver.
4. Connect the remaining signal and power cables to the added receivers, as discussed earlier within this chapter.

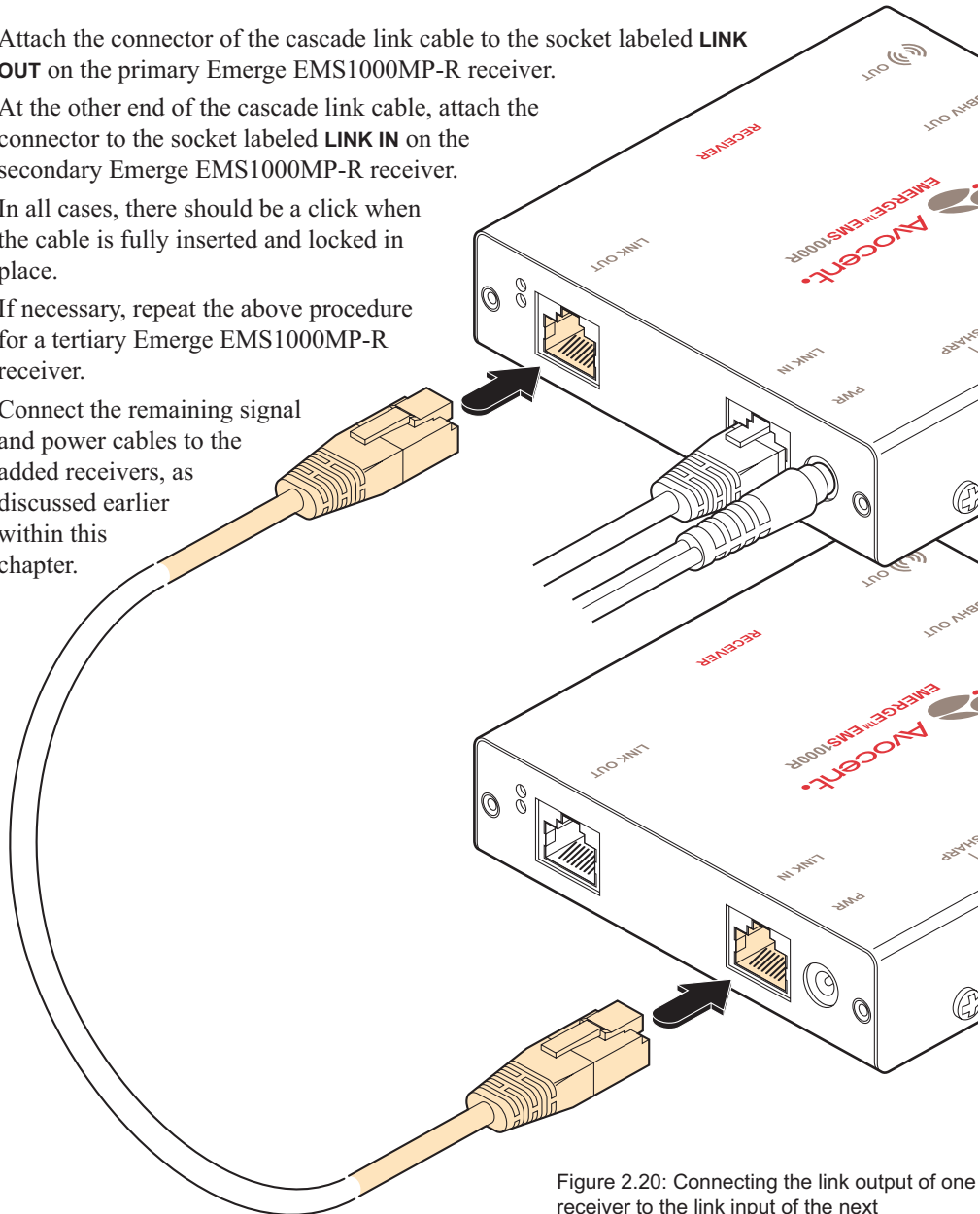

Figure 2.20: Connecting the link output of one receiver to the link input of the next



## Operations

In operation, the Emerge EMS units are designed to be completely transparent - high quality video and audio from the source PC system are played as normal, the only difference is that they are now being seen and heard up to 1000 feet away (600 feet maximum for EMS1000P models).

### Indicators

All Emerge EMS units are equipped with two indicators to confirm operation and, if necessary, assist with quick troubleshooting of potential problems.

The indicators are located on one of the end panels, near to the **LINK** port and operate as follows:

- **RED** When lit, indicates the presence of power into the unit,
- **GREEN** When lit, indicates the presence of a video input into the unit.

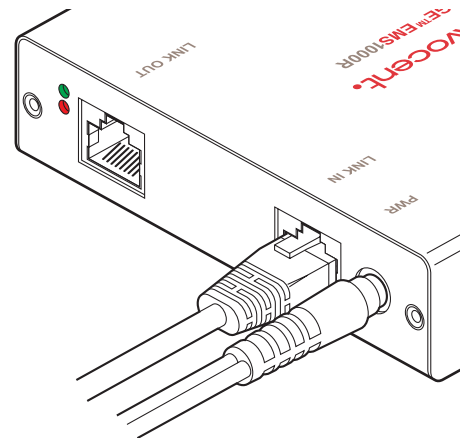

Figure 3.1: Location of the red and green operation indicators

## Adjustments

Video signals are susceptible to the effects of long distance cables and for this reason, every Emerge EMS receiver includes brightness and sharpness adjustment dials. Additionally, the Emerge EMS1000MP-R receivers are also equipped with two extra dials to eliminate the effects of color skew within the video image.

### Brightness and Sharpness Adjustments

The brightness and sharpness adjustments provided on every Emerge EMS receiver allow you to compensate for any losses incurred within long cable links. These two adjustments can be made in any order and independently of each other.

When making adjustments it is necessary to have access to the Emerge EMS receiver and to be able to view one or both connected display screens. Both adjustments, sharpness in particular, are made easier when viewing high contrast images with vertical edges, such as black lines on a white background.

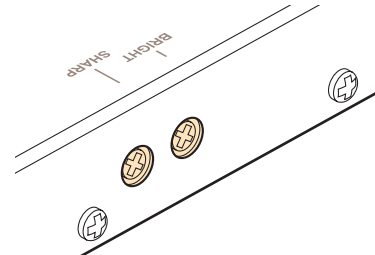

Figure 3.2: Location of the brightness and sharpness adjustment dials

---

**NOTE:** Both video outputs are equally affected by your brightness and/or sharpness adjustments.

---

### To Display a Suitable High Contrast Image

- Open a word processor, type the capital letter ‘H’, or ‘M’ and increase the point size to 72 or higher. For best results, the background should be white and the character should be black.
- A BLACK shadow on the right of the character indicates UNDER compensation.
- A WHITE shadow on the right of the character indicates OVER compensation.

Figure 3.3: Using a high contrast image to assist with sharpness adjustments

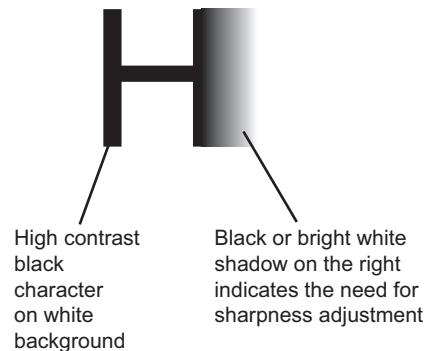

### To Adjust Brightness and/or Sharpness

1. Carefully insert a small screwdriver into the dial labeled **BRIGHT** or **SHARP**, as appropriate.
2. Slowly turn the dial clockwise or counterclockwise and observe the effect shown on the screen. Withdraw the screwdriver when the displayed image is shown at its optimum clarity.
3. If necessary, repeat step 2 for the other dial.

## Skew Compensation Adjustments (Emerge EMS1000MP-R Receivers Only)

The twisted pair cabling used to link the Emerge EMS units consists of four pairs of wires per cable. Three of these pairs are used to convey the red, green and blue video signals. Due to slight differences in twist rate between the wire pairs, the red, green and blue video signals may not arrive at precisely the same time. This effect is visible as separate color shadows on high contrast images and is particularly apparent when using higher screen resolutions over long distances and also when using certain types of category 5e cables.

Skew compensation adjustments are made using two rotary dials, the first affects the relationship between the green and blue color signals (**SKEW GB**) while the second (**SKEW RG**) operates similarly on the red and green signals. Each dial delays one of its stated colors in relation to the other. By using both dials it is possible to correctly align all three colors. The effects of skew are easiest to view and adjust when distinct red, green and blue elements, in close proximity, are present within the screen image. An appropriate test pattern is supplied on the Emerge EMS CD-ROM ([To Display the Supplied Skew Test Pattern](#)) or alternatively you can create your own test pattern as discussed below.

**NOTE:** Both video outputs are equally affected by your skew adjustments.

### To Create a Skew Test Pattern

1. Run any image creation/editing application, such as the Paint program supplied with Windows.
2. Using the image application create three stacked horizontal rectangles (one red, one green and one blue) that fill the width of the screen.
3. Draw a vertical black line down across the colored bars and then repeat this vertical line at intervals along the width of the colored bars. These lines create breaks across the colors and give you more opportunities to view the horizontal position of each color relative to the others.

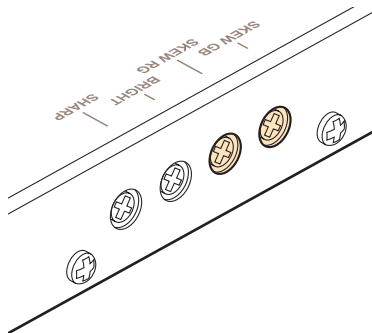

Figure 3.4: Location of the skew compensation adjustment dials

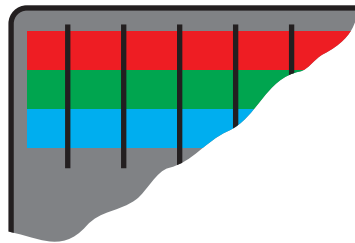

Figure 3.5: Creating a suitable skew test pattern within a paint package

### To Display the Supplied Skew Test Pattern

1. Insert the supplied Avocent CD-ROM into the CD player of the computer.
2. Within Windows, use the My Computer option (usually available as a desktop icon or within the Start menu) to view the contents of the CD-ROM. Double-click the Skew entry to display the standard test pattern. If necessary, maximize the application window so that the image fills the screen.

The screen will show a series of fine red, green and blue crosses which should all be in line, vertically and horizontally- skew affects the horizontal placement of the colors.

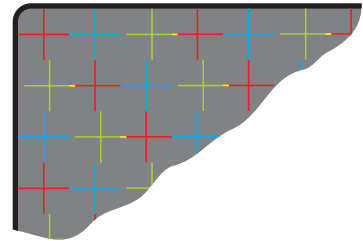

Figure 3.6: The supplied skew test pattern showing green slightly retarded relative to the red and blue

### To Zero the Skew Adjustment Dials

When supplied, the two skew dials are set in their neutral positions. i.e. no delay to either of its colors. However, if the unit has been previously used and adjusted then you may need to relocate the zero point. There are no setting markers around the two skew dials and the dial itself does not have a pointer.

1. Insert a small screwdriver into the skew dial and twist it all the way counterclockwise. Note the position of the dial when it reaches its end point.
2. Rotate the screwdriver fully clockwise and again note the endpoint position of the dial.
3. Now rotate the screw driver counterclockwise until the dial reaches the position that lies midway between the two end points. This is the neutral position.
4. Repeat this procedure for the other skew dial, if necessary.

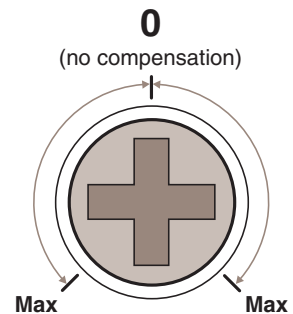

Figure 3.7: A skew compensation dial showing its middle neutral position and its two maximum positions

## To Adjust Skew

Your chances of achieving a successful skew adjustment will be improved if you do the following:

- Ensure that you have a clear view of one or both display screens,
  - Display a suitable RGB test pattern, either the [supplied pattern](#) or a [self-created version](#),
  - Use a screwdriver of an appropriate size to adjust the dials,
  - Begin with both skew dials in their neutral positions - if the unit has been previously used and skew adjusted for an alternative installation, zero the dials as described in the section [To Zero the Skew Adjustment Dials](#).
1. Turn the **SKEW RG** dial clockwise or counterclockwise until you observe that the red and green colors are aligned.
  2. Turn the **SKEW GB** dial clockwise or counterclockwise until you observe that the green and blue colors are aligned.
  3. Your actions in step 2. may alter the Red/Green alignment. If so, go back to the **SKEW RG** dial and turn it clockwise or counterclockwise until you observe that the Red and Green colors are aligned, at which point all of the colors will be aligned.

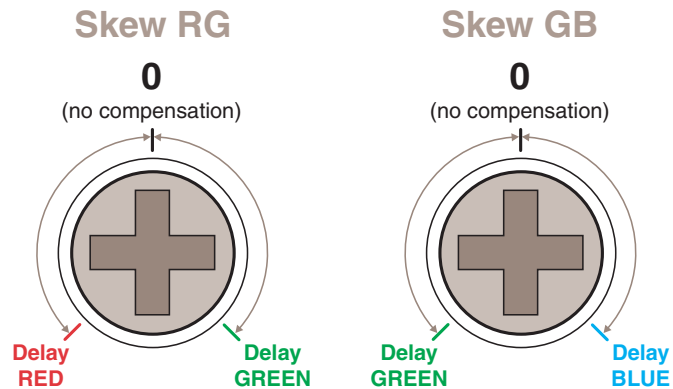

Figure 3.8: The two skew compensation dials showing how they affect each of the colors. When delay is applied to a color, it moves further to the right of the screen.



## APPENDICES

### Appendix A: Technical Support

Our Technical Support staff are ready to assist you with any installation or operating issues you encounter with your Avocent product. If an issue should develop, follow the steps below for the fastest possible service.

**To resolve an issue:**

1. Check the pertinent section of the manual to see if the issue can be resolved by following the procedures outlined.
2. Check our web site at [www.av.avocent.com/support](http://www.av.avocent.com/support) to search the knowledge base or use the online service request.
3. Call the Avocent Technical Support location nearest you.

## Appendix B: Troubleshooting

### **No video image is received at the receiver unit.**

- Check that the both the red power indicators are lit on both the transmitter and receiver units - if they are not, then there is a power problem. Both units require power from their supplied power adaptors.
- Check that the green video input indicators are lit on both the transmitter and receiver units - if one or both are not lit, then a valid video input signal is not present at the input to that unit.
- Check the link cable(s) that connect the transmitter and receiver unit(s) for soundness.
- If possible, try using an alternative twisted pair link connection between the units.
- If the sharpness control is set too high, the monitor may not be able to display a picture. Try reducing the sharpness setting. Please refer to the 'Adjustments' section in the 'Operations' chapter.
- If not already fitted, connect a monitor to the **RGBHV OUT** port of the transmitter unit and check for a correct video image output.

### **Video image at the receiver unit is distorted or shadows appear to the right of displayed objects.**

Adjustments are required to compensate for the length of the twisted pair cable being used. If video problems persist:

- Please refer to the 'Brightness and Sharpness Adjustments' section in the 'Operations' chapter.
- If the overall video image is 'fuzzy' and/or has colored shadows you may need to make skew adjustments (EMS1000MP-R receivers only). This procedure allows you to finely tune the red, green and blue video signal timings to overcome most color separation problems. Please refer to the 'Skew Compensation Adjustments' section in the 'Operations' chapter.

### **Power is applied via the power supply but the unit operation has stopped.**

- Each unit has an internal automatic cut-out fuse to protect against power surges. To reset, remove power from the unit for one second and then reconnect.

### **No sound can be heard on the speakers connected to the receiver unit**

- If not already fitted, connect speakers to the **(Ⓒ) OUT** port of the transmitter unit and check for a correct audio output.
- Check that the both the red power indicators are lit on both the transmitter and receiver units - if they are not, then there is a power problem. Both units require power from their supplied power adaptors.

**INDEX****A**

## Adjustments

- brightness 24
- sharpness 24
- skew compensation 25

## Approval statements ii

## Audio input 8

**B**

## Brightness

- adjustment 24

## BRIGHT dial 24

**C**

## Cable lengths

- link cables 10, 14, 16
- video cables 5

## Cascading

- connection examples 17
- introduction 3
- limitations 16
- receivers - how to 20
- transmitters - how to 18

## Configuration possibilities 1

## Connections

- receiver - cascade 21
- receiver - link in 14
- receiver - power in 15
- receiver - video/audio out 13
- transmitter - cascade 18
- transmitter - link out 10
- transmitter - power in 12
- transmitter - video/audio in 8
- transmitter - video/audio out 9

**D**

## Displays

- connection at receiver 13

**G**

## Green indicator 23

**H**

## High contrast image

- bright & sharp adjustments 24

**I**

## IEC connector 12

## Indicators 23

**L**

## L1 OUT port 11

## Link cable

- receiver 14
- transmitter 10

## LINK IN port 14, 21

## LINK OUT port 10, 21

## Locations

- positioning units 5

**M**

## Monitor

- connection at transmitter 9

## Mounting 6

**P**

## Power adaptor

- connection at the receiver 15
- connection at transmitter 12

## Primary transmitter 16

## PWR port 12, 15

## R

- Rack mount chassis 7
- Rear mounting slot 6
- Receiver cascading 3, 20
- Red indicator 23
- RGBHV IN port 8, 19
- RGBHV OUT port
  - receiver 13
  - transmitter 9, 13, 19

## S

- Safety precautions 4
- Self adhesive feet 6
- Sharpness
  - adjustment 24
- SHARP dial 24
- Skew compensation
  - adjustment 25, 27
  - zeroing the dials 26
- Slot
  - rear mounting 6
- Speakers
  - connection at receiver 13
  - connection at transmitter 9

## T

- Test pattern
  - creating 25
  - supplied 26
- Transmitter cascading 3, 18

## V

- Video image
  - adjustments 20, 24
  - skew compensation 25
- Video input 8
- Video output
  - receiver 13
  - transmitter 9



Avocent®

For Technical Support:

Email: [support@avocent.com](mailto:support@avocent.com)  
[www.av.avocent.com](http://www.av.avocent.com)

Avocent Corporation  
4991 Corporate Drive  
Huntsville, Alabama  
35805-6201 USA  
Tel: +1 256 430 4000  
Fax: +1 256 430 4031

Avocent Asia Pacific  
Singapore Branch Office  
100 Tras Street, #15-01  
Amara Corporate Tower  
Singapore 079027  
Tel: +656 227 3773  
Fax: +656 223 9155

Avocent Canada  
20 Mural Street, Unit 5  
Richmond Hill, Ontario  
L4B 1K3 Canada  
Tel: +1 877 992 9239  
Fax: +1 877 524 2985

Avocent International Ltd.  
Avocent House,  
Shannon Free Zone  
Shannon, County Clare,  
Ireland  
Tel: +353 61 715 292  
Fax: +353 61 471 871

